



BASIC SERIES

USER MANUAL

FOR THE

BS 216

DUAL CHANNEL MASTER STATION



CONTENTS

1.0	GENERAL DESCRIPTION	1
2.0	UNPACKING	1
3.0	MECHANICAL INSTALLATION	1
4.0	MAINS POWER	3
5.0	FRONT PANEL CONTROLS	4
6.0	REAR PANEL CONNECTORS	5
7.0	INTERNAL CONTROLS	5
8.0	CABLING	6
9.0	PARTY LINE, TECHNICAL CONCEPT	7
10.0	GUARANTEE	7
11.0	TECHNICAL SPECIFICATIONS	7

1.0 GENERAL DESCRIPTION

The BS 216 is designed to be a master unit in an ASL intercom system and can be used in portable as well as fixed applications. It incorporates a dual channel intercom line power supply with aux input, a dual channel headset station and uses only 1U of 19" rack space.

This makes the BS 216 very versatile and ideal for use in applications where standard microphone cable is available and ease of setup is of paramount importance.

Each channel has a Volume (listen level) control, a Talk and a Call button with LED indicators and a sidetone trimmer.

The intercom line power supply is fully protected and can drive at least 10 beltpacks operating at full power. The power supply is completely separated from all other functions and in case of power failure the unit can accept line power from an external ASL power supply.

For each channel separately, the intercom line impedance circuitry is installed.

An AUX input at the rear panel, allows injecting external audio signals of line or mic level into the intercom lines. When 'mic level' is selected, +30V phantom power is available at the Aux input connector.

Special attention has been paid to the intelligibility of speech. By applying low noise/high speed circuitry, a speech presence filter and a specially designed headphone amplifier, communication is very comfortable even in environments with high background noise level.

The unique ASL CALL system provides both a flashing red LED and a very distinctive and characteristic sound signal. Only a slight touch of the CALL button will make the LED flash, whilst holding the button for two seconds will activate the call sound signal.

2.0 UNPACKING

The shipping carton contains the parts listed below.

- * The BS 216
- * Power cable
- * Spare fuses
- * User manual

If any are missing contact your dealer.

With the BS 216 will be a small packet of spare fuses. Please keep them in a safe place. There is also one spare fuse included in the mains inlet.

ASL has taken great care to ensure that this product reaches you in flawless condition. After unpacking the unit please inspect for any physical damage to the unit, and retain the shipping carton and relevant packing materials for use should the unit need returning.

If any damage has occurred, please notify your dealer immediately so that a written claim can be initiated. Please also refer to the guarantee section of this manual.

3.0 MECHANICAL INSTALLATION

A vertical rack space of 1U (1.75", 44mm) is required for the BS 216. It is not necessary to provide rear support by extra bracing or shelving.

Adequate ventilation must be provided by allowing sufficient space around the sides and rear of the unit to ensure free circulation of air. Forced cooling is not required.

The power supply is located on the left rear of the unit, and after a period of time it will feel hot to the touch. This is quite normal, and should be no cause for alarm.

Blank Page

4.0 MAINS POWER

The BS 216 may be connected to the mains power outlet to which other audio equipment is connected. The outlet should have a clean earth. Avoid using mains power outlets which also power dimmer controlled lighting equipment.

The used AC power source can be anything from 100 - 240 V AC, 50/60 Hz. There is no need to adjust the unit to the used mains voltage.

The power cord supplied with this unit carries the following information label:

WARNING
This appliance must be earthed

IMPORTANT

The wires in this mains lead are colour coded in accordance with the following code:

green and yellow	Earth / safety ground
blue	Neutral
brown	Live

As the colours of the wires in the mains lead may not correspond with the coloured markings identifying the terminals in your plug, proceed as follows:

- The wire which is coloured green-and-yellow must be connected to the terminal in the plug which is marked with the letter "E", or by the earth symbol which is \perp or coloured green.
- The wire which is coloured blue must be connected to the terminal which is marked with the letter "N" or coloured black.
- The wire which is coloured brown must be connected to the terminal which is marked with the letter "L" or coloured red.

Those units that are supplied to the North American market will have an integral moulded 3 pin connector which is provided to satisfy required local standards.

4.1 SAFETY EARTHING

The green-and-yellow wire of the mains cord must always be connected to the electrical installation safety earth or ground. It is essential for personal safety as well for proper operation of the BS 216 and the other connected stations. This wire is internally connected to all exposed metal surfaces and any rack framework into which this unit might be mounted is assumed to be connected to the same grounding circuit.

4.2 POWERING UP

Powering up procedure:

- Make sure that the red power switch on the left side of the front panel is OFF.
- Connect the power cord to the rear of the station.
- Plug the other end of the power cord into a PROPERLY GROUNDED outlet.
- Turn on the power with the red button, the green power LED will go on, indicating the station is active.

5.0 FRONT PANEL CONTROLS & CONNECTOR

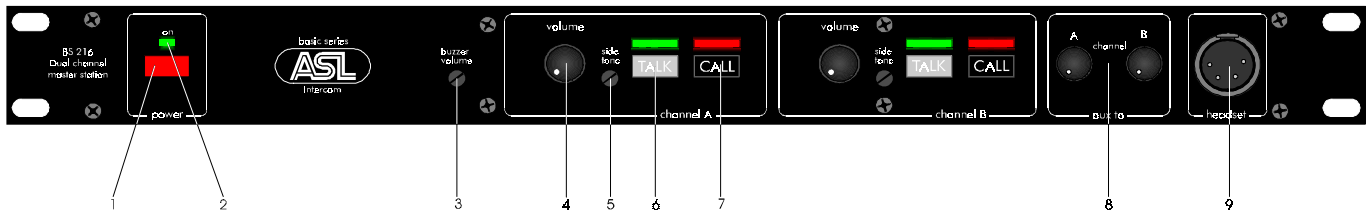

1 POWER ON/OFF switch

Mains power push button for switching ON and OFF the internal power supply.

2 POWER LED

This LED illuminates if line power is supplied by the internal power supply.

3A BUZZER VOLUME trimmer

This trimmer adjusts the volume of the buzzer.

3B BUZZER

This buzzer indicates an incoming or outgoing call. It is activated by pressing a CALL button of the BS 216 or a CALL button of any other station on channel A or B for longer than two seconds. You can adjust its volume with the buzzer volume control.

4 VOLUME A & B control knobs

These knobs adjust the listen level for the headset. Each channel can be adjusted separately.

5 SIDETONE trimmers

These trimmers adjust the level of your own voice as you hear it in your headset.

Adjustment procedure :

- set the trimmer in start position: fully clockwise.
- switch off the microphone of all connected (speaker!) stations.
- switch on the microphone of the required channel.
- turn up the volume of the required channel.
- speak into the headset microphone.
- adjust the listen level by turning the sidetone trimmer.

The operating area is between fully clockwise and minimum level. Adjusting the sidetone does not affect the level of your voice as it is heard by other stations.

6 TALK A & B buttons

These buttons allow you to talk to each channel separately or simultaneously. The large green LED indicates if the talk function is activated.

7 CALL A & B buttons

These push buttons activate the CALL system. A momentary push will send a CALL signal to all stations connected to that intercom channel and the CALL LEDs will start flashing. Press and hold the buttons for 2 seconds will activate the call buzzer. After the CALL button is released the LEDs will continue to flash for a further 2 seconds.

8 AUX VOLUME controls

These knobs adjust the level of the Aux input signal to each of the two intercom lines.

9 HEADSET connector

A XLR-4 type connector for the connection of the local headset. This must have a can impedance of 200 ohms or greater. The mic may be of the dynamic or electret type.

Pin assignments:

1. shield mic. (GND)
2. mic. +
3. phones +
4. phones - (GND)

6.0 REAR PANEL CONTROLS & CONNECTORS

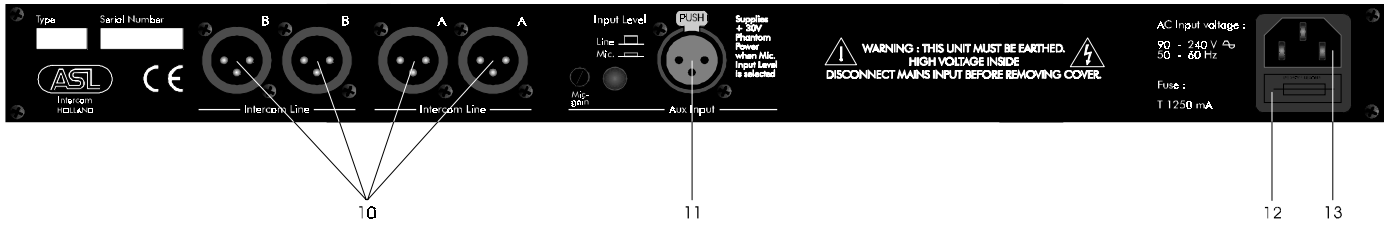

10 A & B line connectors

These XLR-3 type connectors are for connecting the remote-stations, via standard microphone cable. There are two connectors for channel A and two connectors for channel B.

Pin assignments:

1. 0 V / ground shield
2. +30 V power wire
3. audio wire

11 AUX INPUT connector

This XLR-3 type aux input is electronically balanced and accepts audio levels between -16dBu to +22dBu on line level, and -38dBu to +2dBu on mic level.

Pin assignments :

1. 0V / ground
2. Signal +
3. Signal -

When mic level is selected, a +30V DC phantom power is supplied to pins 2 and 3. The mic gain can be adjusted with the trimmer.

12 FUSE

This fuse protects the BS 216 against severe internal damage, in case of malfunction in the power section. To remove the fuse the mains cord must be removed.

It is most important to place the correct fuse in the holder :

mains voltage fuse
100 - 240 VAC T 1250 mA

Spare fuses will be found in the small packet supplied with the unit.

13 MAINS INLET

IEC Mains connector. For correct wiring and operation refer to section 4.0.

WARNING
Before you plug in the mains voltage, check if:
The fuse is correct

7.0 INTERNAL CONTROLS

MIC GAIN

The mic gain can be adjusted internally by a trimmer located on the pcb near to the headset connections.

8.0 CABLING

For the BASIC Series Intercom system the interconnecting cables are of the shielded two-conductor microphone cable type and the intercom line connectors are of the XLR-3 type. Audio and Call signals are on XLR pin 3, DC power is on XLR pin 2. XLR pin 1 is connected to the shield of the cable which functions as the common return for audio and power.

Since the audio signal is transferred in an **unbalanced ★** way, certain rules have to be obeyed when installing the cables of an intercom network. This in order to avoid earth loops and to minimize power loss and the possible effect of electromagnetic fields.

These rules are:

- **Use high quality (multipair) cable.**
For interconnecting user stations, power supplies and accessories in an ASL Intercom network, use high quality shielded two-conductor (minimum 2x 0.30 mm²) microphone cable only.
In case of a two channel intercom network, use high quality microphone 'multipair' cable only, each pair consisting of two conductors (minimum 2x 0.15 mm²) with separate shield. Multipair cable should also have an overall shield.
- **Use flexible cables.**
Use flexible single and multipair microphone cable instead of cable with solid cores, especially when the cable is subjected to bending during operation or installation.
- **Separate cable screen to XLR pin 1.**
The screen of each separate microphone cable and/or the screen of each single pair in a multipair cable, should be connected to pin 1 of each XLR-3 connector. Do not connect this cable screen to the metal housing of the connector or to metal wall boxes (outlets). See page 10 for Earthing Concept.
- **Cable trunks, connection boxes and overall multipair cable screen to clean earth.**
Metal cable trunks, metal connection boxes and overall multipair cable screen should be interconnected and, at one point (the 'central earthing point') in the intercom network only, be connected to a clean earth or a safety earth.
See page 10 for Earthing Concept.
- **Keep metal connection boxes and cable housings isolated from other metal parts.**
Metal housings for intercom cables and connectors should be mounted in such a way that they are isolated from other metal cable and connector housings and from any other metal construction parts.
- **Keep cables parallel as much as possible.**
When two (two channel) units in a network are connected by more than one cable, make sure that these cables are parallel to each other over the whole distance between those units. When using multipair cable, parallelism is ensured in the best possible way.
- **Avoid closed loops.**
Always avoid that cables are making a loop. So-called 'ring intercom' should not physically be cabled as a ring. All cable routes should have a 'star' configuration, with the central earthing point (usually close to the power supply position) as the centre of the star.
- **Keep cables away from electromagnetic sources.**
Keep intercom cables away from high energy cables, e.g. 110/220/380V mains power or dimmer controlled feeds for spotlights.
Intercom cables should cross high energy cables in at angle of 90° only.
Intercom cables should never be in the same trunking with energy cables.
- **Place power supply in a central position.**
In order to avoid unacceptable power losses, place the power supply as close as possible to where most power consumption occurs or, in other words, most user stations are placed.
- **Connect ASL power supply to a 'clean' mains outlet.**
The ASL power supply may be connected to the mains power outlet to which other audio equipment is connected. Avoid using mains outlets which also power dimmer controlled lighting systems.

In case of more complex installations, don't hesitate to contact us. Please send us a block diagram of the planned network with a list of all user stations and their positions, and we are happy to advise you on cabling lay out.

★ See Party Line, Technical Concept

9.0 PARTY LINE, TECHNICAL CONCEPT

ASL's BASIC Series offers a complete two way ('full duplex') communications system. Users of the system are connected via a 'party line'. Master stations (with built-in power supply), beltpacks and power supplies are interconnected via standard microphone cable. One wire is used as an audio line, one as a power line and the screen of the cable functions as earth/return.

Current drive is used for signal transfer. Each station utilises a current amplifier to amplify the microphone signal and place it on the common audio line where, due to the constant line impedance (situated in the power supply between XLR pin 3 and 1), a signal voltage is developed which can be further amplified and sent to the headphones.

This principle has three advantages:

- the use of a single audio line allows several stations to talk and listen simultaneously.
- due to the high bridging impedance offered by each station, the number of stations 'on line' has no influence on the level of the communications signal.
- power and audio to the intercom stations use the same cable.

The Call signal is also sent as a current on the audio line. It develops a DC potential over the line impedance which will be sensed by each station and interpreted as a Call signal.

10.0 GUARANTEE

This unit is warranted by ASL Intercom to the original end-user purchaser against defects in workmanship and materials in its manufacture for a period of one year from date of shipment to the end-user.

Faults arising from misuse, unauthorised modifications or accidents are not covered by this warranty. If the unit is faulty it should be sent in its original packing, to the supplier or your local ASL dealer, with shipping prepaid. A note must be included stating the faults found and a copy of the original suppliers invoice.

THIS PRODUCT WAS DESIGNED, DEVELOPED AND MANUFACTURED BY:

**ASL-intercom BV
MAARSSSEN (UTRECHT) HOLLAND.**

11.0 TECHNICAL SPECIFICATIONS BS 216

POWER SUPPLY	
mains voltage range	100 - 240 V 50/ 60Hz AC
DC output voltage	+30 V +/-5% DC
ripple and noise	< 11 mV rms
max. output current	1.8 A continuous /2.31 A peak

MIC. PREAMP	
mic. impedance	200 ohms
gain	40 dB - 70 dB (adjustable internally)
presence filter	+6 dB at 5 kHz
frequency response	200 Hz - 13 kHz (-3 dB)
V electret mic	+ 9 V DC

HEADPHONES DRIVER AMP	
max. load	200 ohms
max. output level	8 V rms (200 ohms)
max. output power	0.16 W rms (each can)

SIDETONE	
rejection	0 - 30 dB adjustable

BUZZER	
max. SPL	100 dBA

AUX INPUT	
Input impedance	30 Kohms (balanced line level) 4.6 Kohms (balanced mic level)
Nominal input level	-18 dBu to +6dBu (line level) -38 dBu to -14 dBu (mic level)
max. input level	+22 dBu (line level) +2 dBu (mic level)
Phantom power	+30V DC (mic level selected)

DIMENSIONS AND WEIGHT	
width	19" (483 mm)
height	1U (44.5 mm)
depth	124 mm
weight	1.85 Kg

GENERAL SYSTEM SPECIFICATIONS	
intercom line impedance	350 ohms (1kHz) 2.2 Kohms (DC)
intercom line audio level	nom. -18 dBu max. +4 dBu
dynamic range	80 dB
call send signal	2.8 mA
call receive signal threshold	+2.4 V DC
supply voltage	+30 V DC (12 V to 32 V)

Note: 0 dBu = 775 mV into open circuit.

ASL reserves the right to alter specifications without further notice.

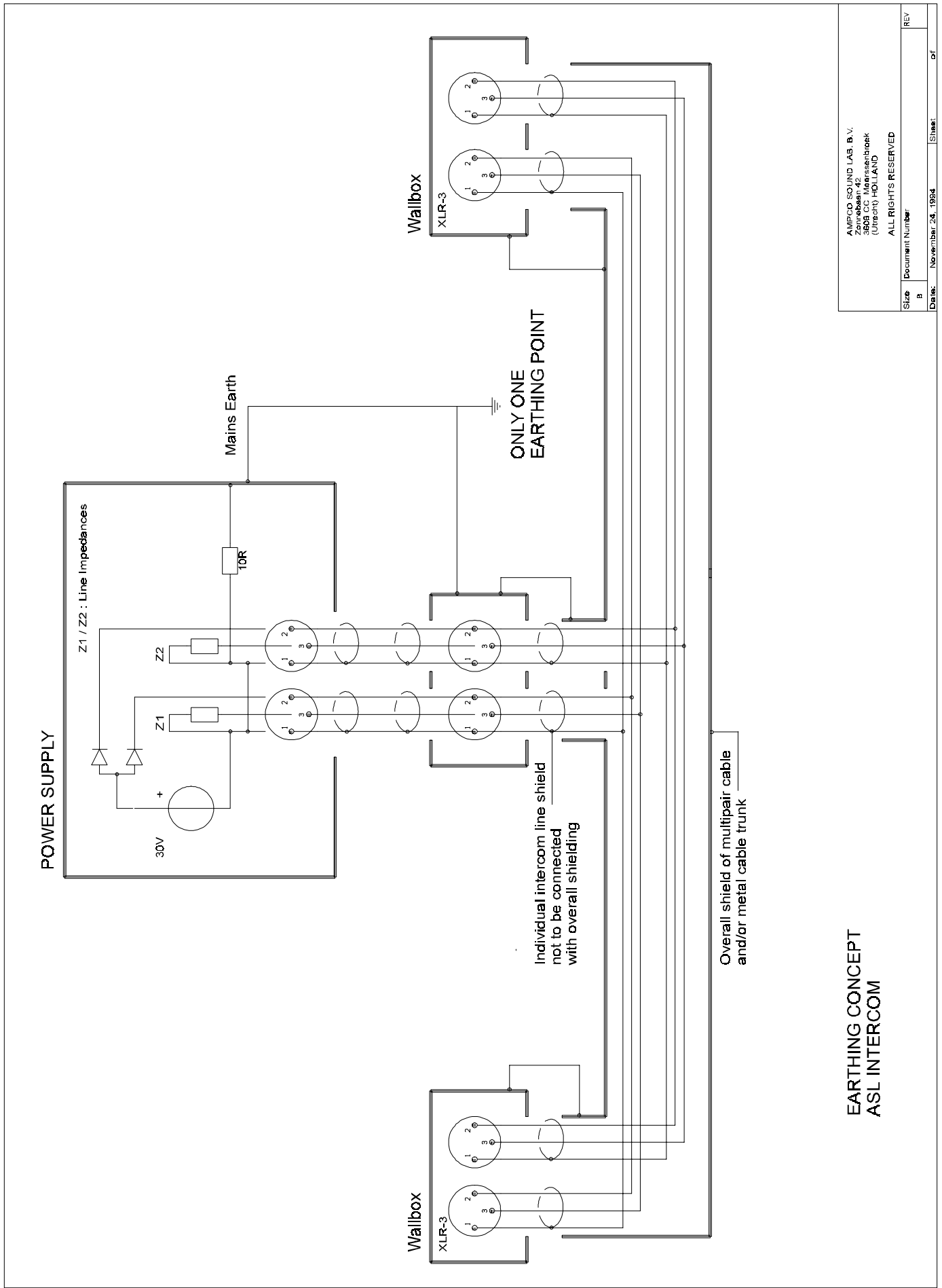

**EARTHING CONCEPT
ASL INTERCOM**

AMPICO SOUND LAB. B.V.
Zandvliet 42
3809 CC Maarssenbroek
(Greenly HOLLAND)
ALL RIGHTS RESERVED

Size	Document Number	REV
B		
Date:	November 24, 1994	Sheet
		of

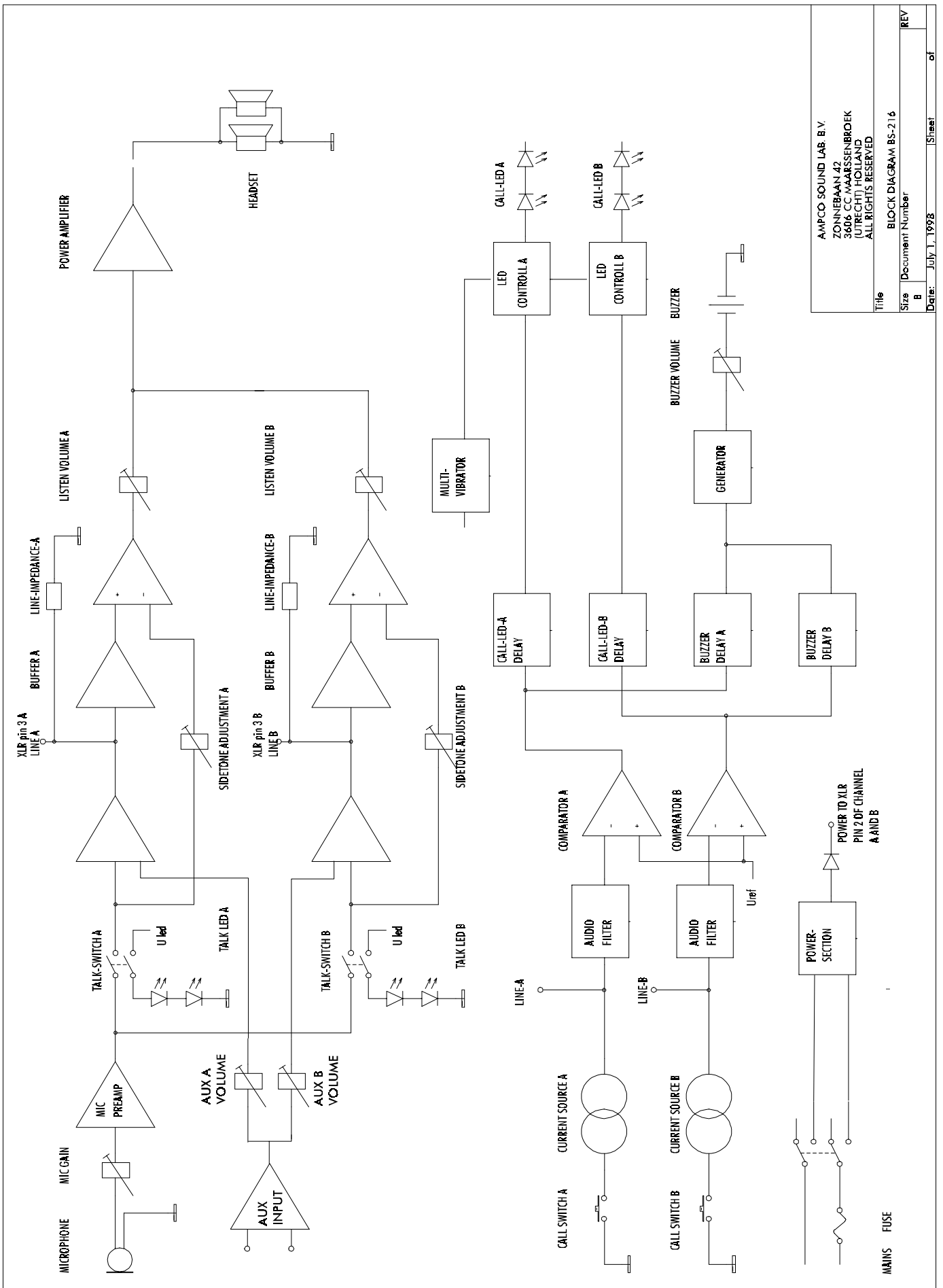

Title: BLOCK DIAGRAM BS-216
 Size: B
 Document Number: B
 Date: July 1, 1998
 Sheet: 1 of 1

AMPCO SOUND LAB. B.V.
 ZONNEBAAN 42
 3606 CC MAARSSENBROEK
 (UTRECHT) HOLLAND
 ALL RIGHTS RESERVED

