

SOUNDFIELD SPS422B

Studio Microphone System

User Guide

System comprises:

- SPS422B Microphone
- SPS422B Rackmount Control Unit - 1U
- Microphone Stand Adapter - Part No. MSA-245
- 20m 12 Pin Microphone Cable (mic to c/unit) - Part No. NN2884
- Mains Lead
- User Guide

Contents

<i>Health and Safety Information</i>	3
<i>Introduction/using the SPS422B</i>	4
<i>Quick start guide</i>	6
<i>Keys to proper placement of SoundField Microphones</i>	8
<i>Getting started</i>	9
<i>Controls</i>	10
<i>Using M/S Mode</i>	12
<i>Surround Sound recording</i>	13
<i>B-Format, how does it work?</i>	14
<i>Recording B-Format with the SPS422B for surround post-production with the SP451 surround processor</i>	16
<i>Interfacing the SPS422B with the SP451 surround processor for live surround recording</i>	17
<i>Optional Accessories</i>	18
<i>Specifications</i>	19
<i>Warranty</i>	20
<i>Quality</i>	22
<i>Shockmount assembly</i>	23
<i>Splitter cable wiring details</i>	25
<i>12 Pin connector wiring details</i>	27
<i>Rycote Assembly Instructions</i>	28

IMPORTANT HEALTH AND SAFETY INFORMATION

- This equipment must be EARTHED.
- Only suitably trained personnel should service this equipment.
- Please read and take note of all warning and informative labels.
- Before starting any servicing operation, this equipment must be isolated from the AC supply (mains) by removing the incoming IEC mains connector.
- Fuses should only be replaced with ones of the same type and rating as that indicated.
- Operate only in a clean, dry and pollutant-free environment.
- Do not operate in an explosive atmosphere.
- Do not allow any liquid or solid objects to enter the equipment. Should this accidentally occur then immediately switch off the unit and contact your service agent.
- Do not allow ventilation slots to be blocked.

Cleaning

For cleaning the front panels of the equipment we recommend anti-static screen cleaner sprayed onto a soft cloth to dampen it only.

Explanation of Warning Symbols

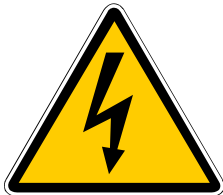

The lightning flash with arrow head symbol within an equilateral triangle is intended to alert the user to the presence of dangerous voltages and energy levels within the product's enclosure that may be of sufficient magnitude to constitute a risk of electric shock or injury.



The exclamation mark within an equilateral triangle is intended to prompt the user to refer to important operating or maintenance (servicing) instructions in the documentation supplied with the product.

This product has a serial number located on the rear panel. Please record the model number and the serial number and retain them for your records.	
Model Number:
Serial Number:

INTRODUCTION

The SPS422B microphone system is based around the same capsule geometry and matrixing principles as the SoundField MKV but the operation has been greatly simplified by linking all the capsule matrixing parameters to just two main controls; **Pattern** and **Width**. The result is a single microphone that can produce optimal results in any situation, mono, stereo or surround but without the technical complexity of the SoundField MKV. Indeed, the SPS422B is as easy to use as conventional studio microphones and has the added benefit of remote pattern and width control allowing the engineer to make most of the critical adjustments while monitoring the result in the control room.

The SPS422B is designed to function as either a variable pattern single (mono) microphone, a variable pattern, variable width, coincident stereo microphone array or for recording full surround sound when used in conjunction with the SP451 Surround Processor or Surround Zone software. This is achieved using four sub-cardioid capsules set in a regular tetrahedron, and by adding or subtracting the outputs from these four capsules in different proportions, it is possible to emulate all possible polar patterns from figure-of-eight through to omni.

Because it is not physically possible to position four separate capsules in the same space, additional compensation circuitry is employed so that the microphone appears to operate at a single point located at the centre of the array. A further benefit of this method of matrixing is that a degree of capsule error cancellation takes place, further improving the performance of these already superb capsules. The practical outcome of this approach to microphone design is the reproduction of a soundfield with a far greater sense of perspective and presence than is possible using conventional microphones.

All the variable parameters may be remotely controlled from the included 1U mains powered control unit and the phase coherent nature of the system ensures absolute phase integrity in mono or mono-compatible applications. A key feature of this microphone system is its high degree of accuracy and its unrivalled ability to capture spatial information. Low noise, proprietary circuitry is used within the control unit and the line level XLR audio outputs are fully balanced.

Both end-fire or side-fire modes are facilitated and the output signals are available in either LEFT/RIGHT (XY), M/S (Mid and Side) or four channel SoundField B-Format (W, X, Y, & Z). A high resolution bargraph metering system provides an accurate level readout of the LEFT/RIGHT signals and of the M/S signals when in M/S mode. For mono and stereo recording applications the engineer will make use of the LEFT/RIGHT output; however, the M/S facility is available for users requiring this specialised facility. Because of the unique single point geometry of the SPS422B, the LEFT/RIGHT output is exactly equivalent to the decoded M/S output which means there is no benefit in using M/S mode unless you have a need to vary the stereo width during post production. For more details on M/S recording see the M/S section of this manual.

For surround recording applications the engineer should use the four B-Format outputs. These contain the three dimensional information (Height, Width, Depth and Sub Bass LFE) required for all current and future surround sound formats. The B-Format signals can be decoded into surround by either the Surround Zone software or the hardware SP451 Surround Processor, both of which output 6 discrete channels (Left, Centre, Right, Surround Left, Surround Right and Sub Bass). The Surround Zone software also provides full stereo re-mixing enabling adjustment of polar patterns, stereo width and all other microphone parameters.

A single lightweight multiway cable is used to connect the microphone to the control unit which as well as carrying the individual capsule signals also supplies the necessary power to the microphone allowing unrestricted use in ENG and OB applications as well as in the studio. Various lengths of microphone cables are available both on and off the drum. Please see the accessories list at the end of this manual.

A separate headphone output is provided to accommodate situations where direct monitoring of the SPS422B's stereo output is required during setting up.

WARNING: The SPS422B microphone is not compatible with the SoundField ST250 control unit and vice versa. SoundField Ltd will not accept any responsibility for damage caused by the interconnection of these units.

USING THE SPS422B

It is recommended that you read this section at least once to fully appreciate the potential of the SPS422B. However, if you want to try the microphone right away, refer to the QUICK START GUIDE on the following page.

The SPS422B may be used in any application where a very high quality mono, stereo or surround recording is required and the stereo output format may be selected as either conventional LEFT/RIGHT or as M/S; M/S mode will require the signals to be decoded using a suitable matrixing system; see the M/S section of this manual. For surround applications the B-Format outputs should be recorded on four tracks or connected directly to the B-Format outputs of the SP451 Surround Processor. For mono applications, the **Width** control should be set to its mono (fully anticlockwise) position.

BEFORE USE

It is essential that the microphone be powered up a few minutes before use to allow the capsule charging process to stabilise. If the microphone has been used recently, the time taken to stabilise may be only a few seconds, but turning the microphone on five minutes or so before it is needed is a good habit to acquire.

In conditions where condensation is likely to be a problem, for example, when bringing the microphone from a cold vehicle to a warm venue, it is advisable to leave the microphone switched on for up to half an hour before use so that the internal heating system can clear the capsules of all condensation.

Though the circuitry generates an extremely low level of noise, the laws of physics dictate that the actual noise performance will vary slightly depending on what pattern and width settings are used. The lowest level of noise occurs when the SPS422B is set up for mono, omni operation but the noise level is exceptionally low in all modes of operation.

USE OF HEADPHONES

The headphone output is provided only for confidence monitoring - it is not intended for qualitative monitoring work and is only suitable for high impedance phones of 400 Ohms or above.

QUICK START

CONNECTING THE SPS422B TO YOUR SYSTEM

Before applying mains power to the SPS422B connect the microphone to the control unit with the provided 12-pin cable. The LEFT/RIGHT XLR outputs of the SPS422B control unit should be connected to two line level inputs of the mixing console (or recorder) and panned hard left and right accordingly. The four B-Format XLR outputs should be connected to four tracks of the multi-track recorder or the B-Format inputs of the SP451 Surround Processor. In the absence of line level inputs the SPS422B has sufficient gain range to feed mic. level inputs. **If connecting to mic. level inputs, ensure that the gain on the control unit is turned fully down (-30 dB) initially.**

Please note the XLR balanced line level outputs are wired as follows:

PIN 1 = screen (earth), PIN 2 = + (positive), PIN 3 = - (negative).

If the SPS422B is to be connected to unbalanced inputs it will be necessary to bridge PIN 1 to PIN 3.

The live side of the microphone is indicated by the SoundField logo.

WIDE IMAGE STEREO RECORDING

For wide image stereo recording such as acoustic guitars, pianos, drum kits, ensembles, vocals etc.

- * Switch on the system and allow to warm up for at least five minutes.
- * Set the **Pattern** control midway (cardioid).
- * Set the **Width** control to its mid position.
- * **M/S** button out.
- * **End Fire** button out (if the microphone is to be used in its normal side entry mode).
- * Use the **Gain** and **Fine Gain** controls to set a nominal 0VU on peak signal levels.

The **Inv** switch should be used if the microphone is suspended in the inverted position, otherwise the left and right outputs will be reversed.

Whilst monitoring a rehearsal, experiment with the **Pattern** control to capture the optimum balance between direct and reflected sound, then adjust **Width** to produce the desired stereo 'spread'. A cardioid pattern will exclude much of the room reflections whereas a figure of eight pattern will pick up the vocal and the room ambience with equal efficiency.

SURROUND RECORDING

For 5.1 surround recording or other multi-speaker playback formats.

- * Switch on the system and allow to warm up for at least five minutes.
- * The **Pattern** and **Width** controls have no effect on the B-Format output material.
- * **End Fire** button out (if the microphone is to be used in its normal side entry mode).
- * Use the **Gain** and **Fine Gain** controls to set a nominal 0VU on peak signal levels.
- * Connect the four B-Format outputs of the SPS422B control unit to the multi-track recorder. An internationally accepted standard is Track 1=W, Track 2=X, Track 3=Y and Track 4=Z.

It is important to note that all controls to the right of the LED bargraphs on the SPS422B control unit (i.e. HP filter, M/S, Pattern & Width) only effect the left/right stereo outputs. Controls to the left of the LED displays (i.e. Gain, Fine Gain, End-Fire and Invert) will effect the B-Format output material. When positioning the microphone bear in mind that sound sources occurring to, for example, the rear left and rear right of the microphone will be reproduced most predominantly by the rear left and rear right speakers in a surround monitoring playback situation.

SINGLE TRACK MONO RECORDING

For overdubbing on single tracks of a multi-track recorder or conventional mono recording.

- * Switch on the system and allow to warm up for at least five minutes.
- * Set the **Pattern** control midway (cardioid).
- * Set the **Width** control fully anticlockwise to zero (mono).
- * **M/S** button out.
- * **End Fire** button out (if the microphone is to be used in its normal side entry mode).
- * Use the **Gain** and **Fine Gain** controls to set a nominal 0VU on peak signal levels.

The **Inv** switch will have no effect when the microphone is being used in mono mode.

In mono mode one or both outputs from the control unit may be routed to the relevant track of the recorder. Whilst monitoring a rehearsal, experiment with the **Pattern** control to capture the optimum balance between direct and reflected sound. A tight cardioid pattern will exclude much of the room reflections whereas an omni or figure of eight pattern will pick up both the vocal and the room ambience.

Keys to Proper Placement of SoundField Microphones

With SoundField microphones, it is too easy to be lulled into complacency by the excellent stereo pickup they provide. The temptation is to put it up, turn a few knobs, and go with it. However, with a little more attention to detail this “good” sound always will become even better.

Be sure to set the Orientation buttons to tell the controller how the mic is facing. Then, before ever opening the mic up to stereo, it is important to listen to the mic as a *monophonic* pickup. Set the Pattern control to Omni and the Width control to 0° and listen to the overall sound. Pay particular attention to the balance within the sound source - i.e. the balance among the performers, the relationship of direct-to-reverberant sound, extraneous noises, etc. If it doesn't sound right, move the mic around until it does. You also can adjust the Pattern control to focus more on the sound source (and less on the surrounding environment) if necessary. Remember that the essence of SoundField microphones is based on the Mid/Side technique, where the Mid microphone provides the basic sonic balance. Therefore, once it sounds good in mono, it always will sound great in stereo; the converse, however, is not necessarily true.

Only after you are satisfied with the mono pickup, should you open-up the mic into stereo. Set the Pattern control to the polar pickup you think will be a good starting point and adjust the Width control for your desired stereo image. You can adjust both controls to achieve exactly the right stereo perspective for your recording.

Pay particular attention to the direct-to-reverberant sound. Remember that too much reverb makes a recording sound “mushy” and vague. The beauty of SoundField microphone systems is their unequalled clarity and articulation. Don't waste this by including too much extraneous sound — unless, of course, that is what you *want* to do. Also keep an eye on the level meters to be sure that you are not likely to overload the microphone's electronics.

GETTING STARTED

The microphone connecting cable is fitted with two threaded 12 pin connectors and these should be inserted into the microphone and the SPS422B control unit and the threaded collars hand-tightened. Connect the microphone to the control unit before switching on the mains, and once powered up, leave the system several minutes to stabilise. The microphone can be attached to the stand with the provided stand adaptor or alternatively, to provide better isolation from vibration, the optional SoundField Shock Mount (Part No. HW2909).

For close-up vocal work, it is highly recommended to use the optional SoundField VPS150 Pop Screen. This should be positioned between 10 and 15 cm from the microphone.

The outputs of the SPS422B control unit should be connected to the line level inputs of the mixing console or recorder using high quality, balanced XLR screened cables. However, where it is not possible to access line level inputs, the SPS422B has sufficient gain range to feed mic. level inputs. **If connecting to mic. level inputs, ensure that the gain on the control unit is turned fully down (-30 dB) initially.**

To configure the microphone as a coincident cardioid stereo pair, set the Pattern and Width controls to their mid-way positions and ensure the M/S switch is out. Press End if end-fire operation is required, otherwise leave this button out and use the microphone in side-fire mode. If it is necessary to suspend the microphone in an inverted position, also press the **Inv** button.

Orientation Guide

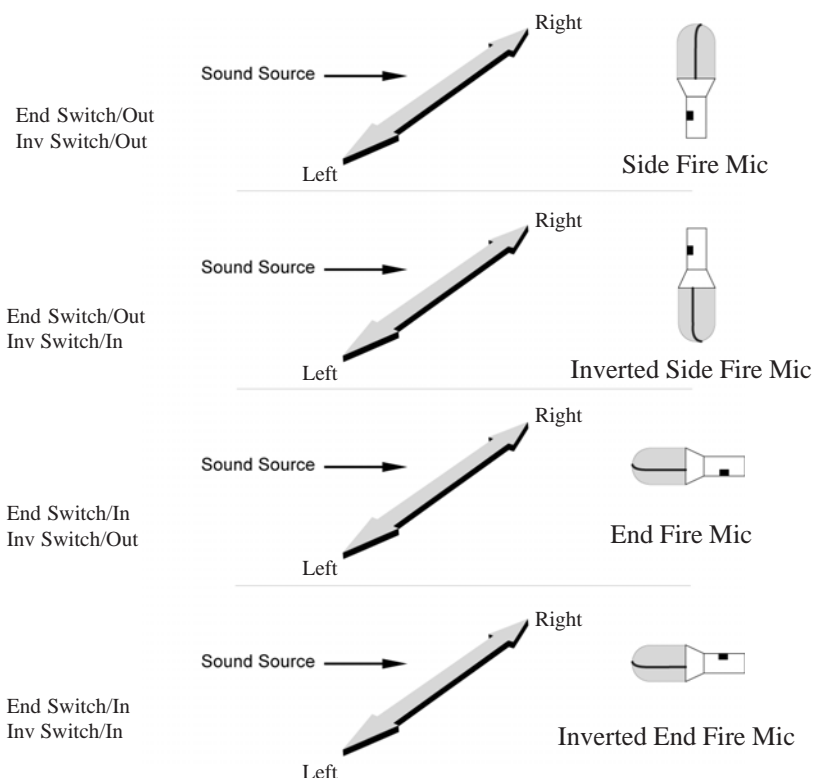

The **Gain** settings should be adjusted while watching the bargraph meters so that peak levels reach a nominal 0dB on the scale. **Gain** sets the mic amp gain in 10dB increments from 0 to -30dB while the **Fine Gain** control provides continuous adjustment between these steps. An 80Hz, 18dB/octave high-pass filter may be switched in using the **Filter** button where low frequency noise (such as distant traffic or air conditioning rumble) may be a problem.

CONTROLS

FRONT PANEL

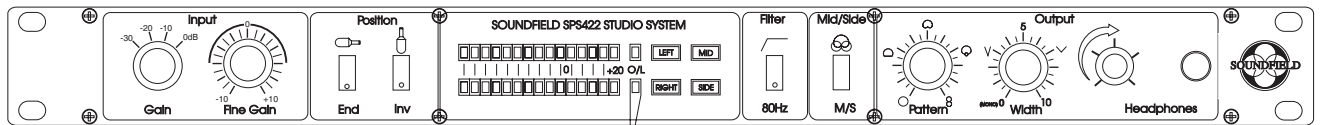

Gain

: sets the gain of the mic amplifier in 10dB switchable steps from -30 to 0dB.

Fine Gain

: used to continually fine tune the gain of the mic amplifier over a 10dB range once the switchable Gain range has been set.

End

: when in, sets the microphone to end-fire operation. In end-fire mode, the Pattern and Width controls operate exactly as they do in the side-fire mode. See diagram for correct orientation on page 6.

Inv

: for use with the side-fire mode to allow the microphone to be physically inverted without this causing the left and right output signals to be transposed. This switch should be in when the microphone is suspended over a sound source to keep the left/right perspective accurate.

Meters

: monitor the LEFT/RIGHT output levels or the Mid and Side signals when in M/S mode.

Filters

: when in, activates a 18dB per octave low cut filter acting at 80Hz. This affects both outputs and, in addition to helping attenuate unwanted low frequency noise, it may also be helpful when close-miking vocals.

Mid/Side

: when in, the controller provides MS format outputs which will need to be decoded using a suitable matrix system. When out, the outputs provide a conventional LEFT/RIGHT (XY) format.

Pattern

: sets the polar pattern of the array. In effect, the control unit decodes the capsule information into two 'virtual' microphones which may be continually varied as a pair from omni, through cardioid, to figure-of-eight patterns. In M/S mode, the Pattern control sets the polar pattern of the equivalent XY pair.

Width

: adjusts the angle between the two 'virtual' microphones. When set fully anticlockwise, the SPS422B produces a mono output from both output sockets.

Headphones

: sets the volume level of the adjacent headphone output socket. The output is a standard, stereo quarter inch jack (TRS) and is for use with headphones having an impedance of 400 ohms or greater. It should be noted that the headphone output is not to the same high specification as the main outputs and is only intended for confidence monitoring.

REAR PANEL

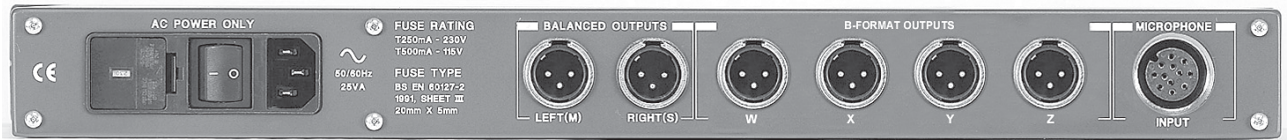

POWER

: rocker switch turns on the mains supply when set to the 1 position.

MAINS INLET

: accepts standard IEC, three-wire mains lead. Ensure supply voltage matches that of the controller before switching on.

STEREO OUTPUTS

: Balanced line level XLR outputs wired to the pin 2 hot standard. In M/S mode, the Left output carries the Mid signal and the Right output the Side signal. If connected to a mixer mic input, the phantom power should be switched off.

B-FORMAT OUTPUTS

: for surround recording and can be connected to a multi-track recorder or SP451 Surround Sound Processor / Surround Zone software for live or post production surround decoding.

MICROPHONE INPUT

: for use only with the SPS422B microphone using the cable supplied.

USING M/S MODE

M/S or 'Middle and Side' is a method of combining the outputs of a forward firing cardioid (or occasionally an omni) microphone with a laterally mounted figure of eight microphone to provide a stereo output. A simple sum and difference matrix circuit is required and these are commercially available as M/S decoders.

Mathematically, there is no difference between decoded M/S and conventional LEFT/RIGHT XY stereo signals if theoretically perfect microphones are used, but many engineers feel that M/S produces more natural results with most 'real-life' microphones as the centre image is directly on-axis to the mid microphone. The unique SoundField capsule geometry and matrix circuitry ensures that both the MID centre mono component and the SIDE signal are resolved accurately with no phase discrepancies, and that the MID centre signal level remains constant when the width is being varied.

M/S mode is particularly useful when making live recordings as it allows the stereo image to be adjusted at the post production stage. The MID signal is recorded onto one track of the stereo machine and the SIDE signal on the other; it helps to stick to a convention here and it is suggested to always use the left channel to record the MID signal and the right channel the SIDE signal.

As it stands, this recording will not produce a stereo image when replayed - it must first be decoded using a 'sum and difference' matrix. The two sides of the stereo signal are reconstituted by adding the SIDE signal to the MID signal to produce one side of the image and subtracting the SIDE signal (using phase inversion) from the MID signal to produce the other side. By adjusting the level of the SIDE component, the stereo width can be made as wide or as narrow as is desirable and, by omitting the SIDE component altogether, a pure mono signal is available. Because of the ability to modify the stereo image in this way, it is recommended that any M/S recordings be made with the **Pattern** and **Width** controls set to their midway positions.

Commercial M/S decoders provide the most accurate means to decode an M/S recording, but in situations where none are available, it is possible to achieve similar results using a mixing console equipped with phase invert buttons. This requires the use of three mixer channels and is arranged as shown below.

MS DECODING USING MIXER CHANNELS

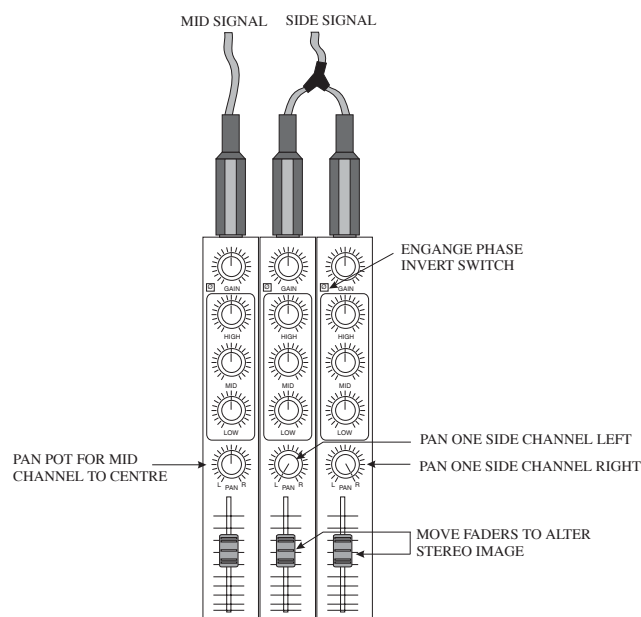

SURROUND SOUND RECORDING

The SPS422B microphone system and the SP451 processor are very easy to use. The four B-Format outputs from the microphone system may either be fed directly to the SP451 for 'live' surround recording or recorded to a multi-track recorder and then played back into the SP451 for post-production processing. The SP451 uses these signals to create up to three 5.1 surround microphone arrays.

The five microphones of this virtual array represent the conventional Front mic positions at Left (-45 degrees), Centre (0 degrees), and Right (+45 degrees); the surround positions are at Rear Left (-135 degrees) and Rear Right (+135 degrees). The LFE (sub-bass) output is derived from its own virtual omni microphone.

By processing the B-Format signals via the SP451, the mixing engineer has the ability to create the optimum surround mic array configuration. Equally important, the same B-Format signals can be processed in a variety of ways to meet the broad range of needs imposed by differing audio delivery formats. Thus, a stereo music recording for CD production, a mono feed for AM radio, and a surround soundtrack for video or DVD all can be created either independently or simultaneously. All this can be done either in 'real time' or during any stages of post-production, affording the mixing engineer the ability to create the ideal sonic perspective under the controlled conditions of the production studio, rather than forcing a decision during the original recording session that later may prove to be less than ideal.

In order to avoid the confusion and complexity that could result from an infinitely variable system (we all are familiar with the 'too many knobs' syndrome) the SP451 processor uses plug-in MAP (Microphone Array Pattern) cards to define the basic default polar patterns and angles of the virtual microphone array, and provides the user with just the front panel controls needed to optimise this initial array for any specific application quickly and easily. For example, the Front and Rear microphone pairs in a 5.1 array may be adjusted ± 45 degrees from their default angles, to suit any desired music and/or video reproduction system for surround sound.

All of the outputs are at line level and represent the discrete outputs from the microphones of the virtual array. No further SoundField processing is required once the signals leave the SP451.

The Rear Focus control enables the polar patterns of the Rear microphone pair to be varied. This provides significant adjustment of the imaging and 'spaciousness' of the surround channels.

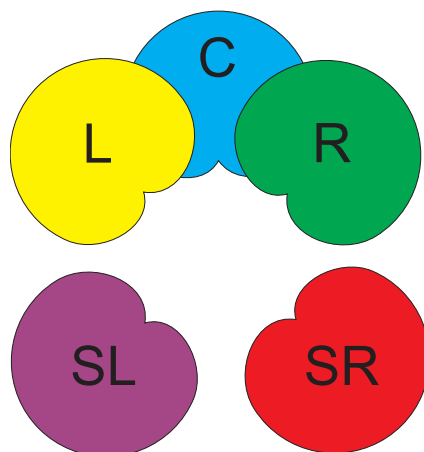

The five cardioid MAP card supplied as standard with the SP451 Surround Processor.

B-FORMAT - HOW DOES IT WORK?

SOUNDFIELD B-FORMAT:



The SoundField Four Capsule Array

The capsules are placed tightly together to eliminate the phase problems associated with 'spaced' multi-microphone set-ups.

From a single point source sound is received from all directions, reproducing a realistic listening experience.

The four outputs from the capsules of SoundField microphones (called the A-Format signals) are converted by the MKV, ST250 and SPS422B processors into four components known as SoundField B-Format. These convey all of the information of the entire soundfield, and are the three directional vectors - fore/aft, left/right, up/down - and absolute pressure.

The signals from the four capsules are fed to the microphone's control unit where it is converted into four channels of SoundField B-Format, known as W, X, Y and Z.

Mono, Stereo, Mid-Side, 5.1 and all future surround formats can be derived from this information.

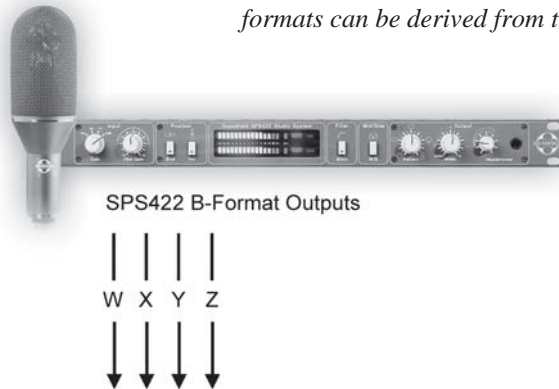

B-Format is three dimensional acoustical information and consists of three figure of eight polar patterns called X, Y and Z plus one omni called W.

X gives Front to Rear depth information, Y gives Left to Right horizontal information and Z gives vertical height information. From the omni W sub-bass (LFE) is extracted. SoundField are the only microphones in the world that generate B-Format.

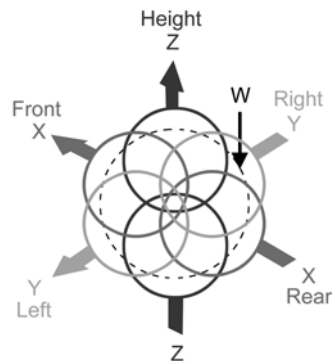

B-Format Illustration

The four channels of the B-Format signal are represented by three bidirectional and one omnidirectional pickups, all centred at a single point in space, and are labelled W (pressure), X (fore/aft), Y (left/right), and Z (up/down). These signals contain all of the information required to describe a soundwave and are the essential elements needed to create any conventional mono, stereo, or surround format where the microphone positions and polar patterns can be fully variable. By recording the four B-Format outputs from a MKV, ST250 or SPS422B, these components can be preserved for subsequent production and processing of current and all future surround formats.

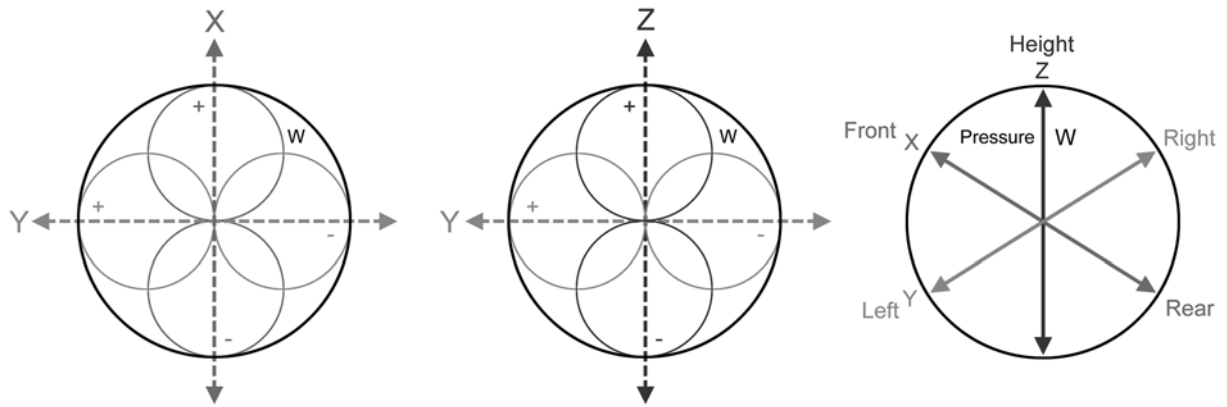

X: HORIZONTAL VECTOR: FRONT/REAR PRESSURE-GRADIENT COMPONENT

Y: HORIZONTAL VECTOR: LEFT/RIGHT PRESSURE-GRADIENT COMPONENT

Z: VERTICAL VECTOR: HEIGHT PRESSURE-GRADIENT COMPONENT

W: PRESSURE (OMNIDIRECTIONAL) COMPONENT

RECORDING B-FORMAT WITH THE SPS422B FOR SURROUND POST-PRODUCTION WITH THE SP451 SURROUND PROCESSOR

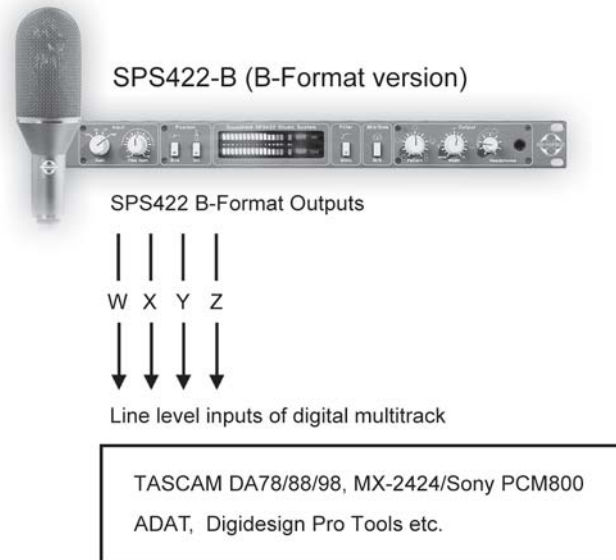

The advantage of recording an acoustic event in B-Format is that it can be de-coded by the SP451 processor into the current 5.1 surround format or any future 6.1, 7.1, etc format (with the appropriate MAP cards fitted into the SP451) and therefore is ideal for 'surround archiving'. When the four tracks of B-Format are played back through SP451 in a post-production environment, many parameters of the selectable mic array can be adjusted after the event. These include changing the width of both the front and rear pairs of microphones, mixing sound sources occurring at the front of the mic array towards the rear and the choice and instant comparison of up to three different mic arrays.

It is also common to record the Left/Right stereo outputs from the SPS422-B processor onto a further two tracks of the multitrack. In this way both a 'surround master' and a 'stereo master' can be derived from a single DTRS cassette. Some sound engineers, if they have the facility, will as insurance also simultaneously record two 'spot mics' on a further two tracks. These are usually focused on 'quieter' sound sources which may be too low in level in the natural acoustic balance of the performance, and if necessary can be introduced to the mix in post-production.

INTERFACING THE SPS422B WITH THE SP451 SURROUND PROCESSOR FOR LIVE SURROUND RECORDING

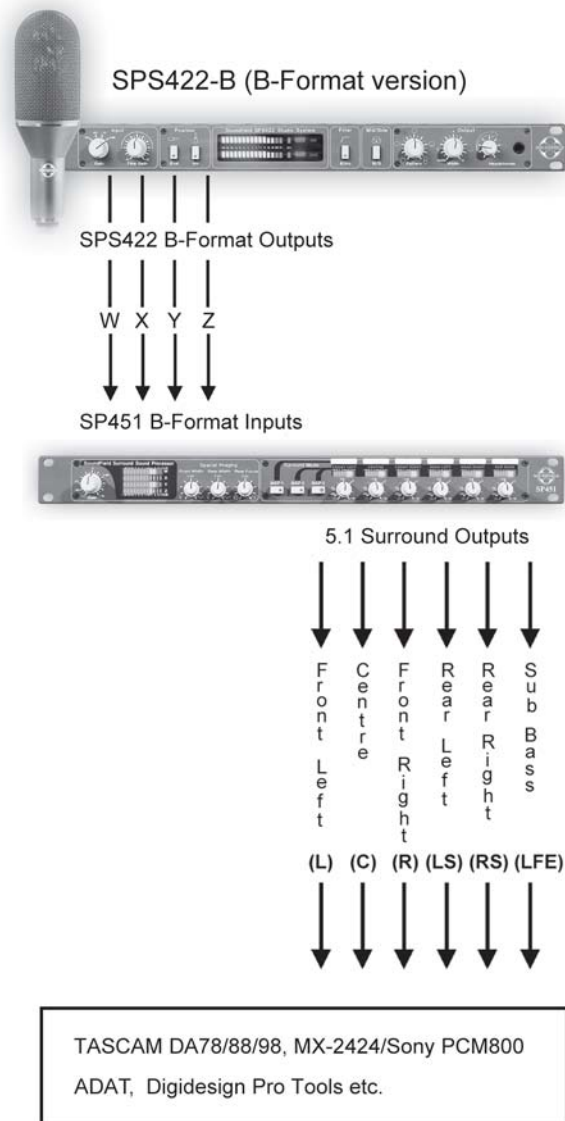

In this configuration the SPS422-B/SP451 combination will deliver six discrete channels of 5.1 surround sound. It is a very quick and effective way to record surround. After some practice and once you know how to get the best from your system, it will yield consistent results. Although not vital, it is a big advantage to be able to monitor in full surround when choosing your mic position. It is important to bear in mind when recording this way that the result is, in effect, a 'finished product'. One way to retain post-production capability is to also record the B-Format at the same time as the six channels of surround. Of course, to do this you will require ten tracks to record on. Again, a stereo master can also be recorded directly from the left/right outputs of the SPS422B processor.

OPTIONAL ACCESSORIES

HW2909	Shock Mount Assembly
755-007	Spare Elastic Supports for HW2909 (full set)
490-090	Leather Microphone Case
762-001	Foam Windshield
VPS150	Studio Vocal Pop Screen
MSA-245	SoundField Microphone Stand Adaptor

FLIGHT CASES

FCMKV	MKV Flight Case – suitcase style
FCSPS422	SPS422 Flight Case – suitcase style
FCSPS422451	2U R/Mount Flight Case for SPS422B/SP451 mic & accessories

440-188	ST250 Zero Field Case
FCMKV451	3U R/Mount Flight Case for MKV/SP451 mic & accessories

RYCOTE KIT COMPRISING OF:

430-385	Rycote Suspension with Pistol Grip
430-384	Rycote 140mm Windshield
440-182	Rycote Mounting Kit

All three above items are required for one complete Rycote Kit

430-398	Optional Rycote Windjammer (to fit 430-384)
---------	---

CABLES AND CONNECTORS

NN2882	5 Metre Microphone Cable
NN2883	10 Metre Microphone Cable
NN2884	20 Metre Microphone Cable
NN2885	50 Metre Microphone Cable/plastic drum
NN2886	100 Metre Microphone Cable/metal drum
NN2877	Mic Splitter Cable 12 PIN Male to Female XLRs
NN2878	Mic Splitter Cable 12 PIN Female to Male XLRs
410-059	12 PIN Panel Mount Connector - Male
410-045	12 PIN Panel Mount Connector - Female
410-043	12 PIN In Line Connector - Male
410-044	12 PIN In Line Connector - Female
310-353	SoundField 12 Core Mic Cable/Metre

SPS422B SPECIFICATION

SPECIFICATIONS (+/- 1dB)

Microphone front sensitivity at -30dB , trim 0	— — — —	122dB
Microphone acoustic line up at 0dB gain , trim 0	— — —	80dB SPL
Maximum input for less than 0.5% THD	— — — — —	145dB SPL
Frequency range	— — — — —	20Hz - 20kHz
Frequency range with 80Hz High Pass Filter	— — —	80Hz - 20kHz
Equivalent self noise, IEC 179 (cardioid)	— — — —	14dB - A SPL
Control Unit outputs at line-up	— — — — —	0dBu , Balanced
Maximum Output levels	— — — — —	+22dBu
Minimum Loads		
Stereo and B-Format Outputs	— — — —	600 Ohms
Headphones	— — — — —	400 Ohms/Side
Output connections (Balanced / Line Level)	— — — —	XLR Connectors
Output XLR's wired: PIN 1 = screen (earth), PIN 2 = + (positive), PIN 3 = - (negative).		
If the SPS422B is to be connected to unbalanced inputs it will be necessary to bridge PIN 1 to PIN 3.		
Output Impedance	— — — — —	100 Ohms Balanced
Powering	— — — — —	Mains 230V/115V

As a policy of continually improving our products is pursued, specifications are subject to change without notice.

Humidity and Condensation

Condensation which is caused by rapid changes in humidity and cold, damp conditions can be a problem to ALL polarised capacitor microphones. Moisture from the atmosphere or from the breath, if used close to the mouth, may condense on the capsules resulting in noise and reduced signal. The SPS422B microphone includes a heater in the capsule cluster to minimise this effect and normal performance is restored when this moisture has completely evaporated. The heater is only operative when the unit is powered. It is therefore advisable when the microphone has been stored in a cold place, such as in a vehicle overnight, to bring the microphone into a warm dry environment prior to use and full performance will be achieved more quickly. It is also desirable to fit the foam windshield if the microphone is used at close range, and to use an anti-pop screen at about 20cm distance.

WARRANTY

Limited Liability

SOUNDFIELD LTD., HEREIN AFTER KNOWN AS THE MANUFACTURER, GUARANTEES THIS EQUIPMENT FROM DEFECTS IN MATERIAL AND WORKMANSHIP UNDER NORMAL USE AND SERVICE FOR A PERIOD OF ONE YEAR. THIS GUARANTEE EXTENDS TO THE ORIGINAL PURCHASER ONLY AND DOES NOT APPLY TO FUSES OR ANY PRODUCT OR PARTS SUBJECTED TO MISUSE, NEGLIGENCE, ACCIDENT OR ABNORMAL CONDITIONS OF OPERATION. THE GUARANTEE BEGINS ON THE DATE OF DELIVERY TO THE ACTUAL PURCHASER OR TO HIS AUTHORISED AGENT OR CARRIER.

IN THE EVENT OF FAILURE OF A PRODUCT COVERED BY THIS GUARANTEE, THE MANUFACTURER OR THEIR CERTIFIED REPRESENTATIVES WILL REPAIR AND CALIBRATE EQUIPMENT RETURNED PREPAID TO AN AUTHORISED SERVICE FACILITY WITHIN ONE YEAR OF THE ORIGINAL PURCHASE AND PROVIDED THAT THE GUARANTORS EXAMINATION DISCLOSES TO ITS SATISFACTION THAT THE PRODUCT WAS DEFECTIVE, EQUIPMENT UNDER THIS GUARANTEE WILL BE REPAIRED OR REPLACED WITHOUT CHARGE. ANY FAULT THAT HAS BEEN CAUSED BY MISUSE, NEGLIGENCE, ACCIDENT, ACT OF GOD, WAR OR CIVIL INSURRECTION; ALTERATION OR REPAIR BY UNAUTHORISED PERSONAL; OPERATION FROM AN INCORRECT POWER SOURCE OR ABNORMAL CONDITIONS OF OPERATION, WILL NOT FALL UNDER THIS GUARANTEE. HOWEVER, AN ESTIMATE OF THE COST OF THE REPAIR WORK WILL BE SUBMITTED BEFORE WORK IS STARTED.

THE MANUFACTURER SHALL NOT BE RESPONSIBLE FOR ANY LOSS OR DAMAGE, DIRECT OR CONSEQUENTIAL, RESULTING FROM MACHINE FAILURE OR THE INABILITY OF THE PRODUCT TO PERFORM.

THE MANUFACTURER SHALL NOT BE RESPONSIBLE FOR ANY DAMAGE OR LOSS DURING SHIPMENT TO AND FROM THE FACTORY OR ITS DESIGNATED SERVICE FACILITY.

THIS GUARANTEE IS IN LIEU OF ALL OTHER GUARANTEES, EXPRESSED OR IMPLIED, AND OF ANY OTHER LIABILITIES ON THE MANUFACTURERS PART. THE MANUFACTURER DOES NOT AUTHORISE ANYONE TO MAKE ANY GUARANTEE OR ASSUME ANY LIABILITY NOT STRICTLY IN ACCORDANCE WITH THE ABOVE.

THE MANUFACTURER RESERVES THE RIGHT TO MAKE CHANGES OR IMPROVEMENT IN THE DESIGN AND CONSTRUCTION OF THIS UNIT WITHOUT OBLIGATION TO MAKE SUCH CHANGES OR IMPROVEMENTS IN THE PURCHASER'S UNIT.

ANY DISPUTE ARISING FROM THIS WARRANTY SHALL BE SUBJECT TO THE LAWS OF ENGLAND.

What to do if a fault is found

If a fault develops in the unit, notify SoundField Ltd. or their nearest service facility giving full details of the difficulty. On receipt of this information, service or shipping instructions will be forwarded to you. No equipment should be returned under the warranty without prior consent from SoundField Ltd or their Authorised Representative.

SHIPPING INFORMATION

Authorised returns should be prepaid and must be insured. All SoundField products are packaged in specially designed containers for the best possible protection. If the unit is returned the original container should be used. If this is not possible, a new container can be obtained from SoundField Ltd. please specify the model number when requesting a new container. If the specially designed container is not used ensure that a suitable rigid container of adequate size is used, wrap the instrument in paper and surround it with a good thickness of shock absorbing material.

Claim for damage during transit

The instrument should be thoroughly inspected immediately upon delivery to the purchaser. If the instrument is damaged in any way a claim should be filed with the carrier immediately. A quotation to repair shipment damage can be obtained from SoundField Ltd. or their Certified Representative. Final claims and negotiations with the carrier must be completed by the customer.

Applications problems

SoundField Ltd. will be happy to answer all applications questions to enhance your use of this equipment. Please address all correspondence to:

SoundField Ltd.
Charlotte Street Business Centre
Charlotte Street
Wakefield, West Yorkshire
WF1 UH
ENGLAND
Tel: +44 (0) 1924 201089
Fax: +44 (0) 1924 290460
E-mail: info@soundfield.com

QUALITY ASSURANCE AND SERVICE POLICY

Over the years SoundField products have gained an enviable reputation for their quality of design, performance and reliability, however, in the unlikely event that problems are encountered with this unit, please contact SoundField Service at the appropriate address below or alternatively inform one of our world wide network of distributors who will be able to assist with any of your queries.

SoundField Ltd.
Charlotte Street Business Centre
Charlotte Street
Wakefield, West Yorkshire
WF1 UH
ENGLAND
Tel: +44 (0) 1924 201089
Fax: +44 (0) 1924 290460
E-mail: info@soundfield.com

All SoundField products are sold subject to our 'General Conditions of Sale' and the purchaser should note 'that the equipment is not being sold to him to meet his individual requirements and it is therefore the buyer's responsibility to ensure that the purposes and functions of the equipment meet his requirements prior to purchase.' However, we would non-the-less be grateful to receive any constructive criticism or ideas for additional features which you feel might enhance the usefulness of our product in the studio environment.

SPS422B Microphone Shockmount Assembly Instructions

List of Parts

- 1 x Geodesic Suspension Cradle
- 2 x Elastic Loops
- 1 x SPS422B Microphone Holder
- 1 x Stand Mounting Knuckle Joint - 2 pieces, slotted nut and bolt
- 1 x Allen Screw - 4mm hexagonal head
- 2 x Knurled Head Screw (Fischer Boom)

Stand Mounting

- 1** Fit the holder into the cradle (Figure 1). The top four hooks on the holder should clip onto one elastic loop and the bottom four onto the other. See Figure 4 for position.
- 2** Adjust the tension of the elastics so that the holder is held equidistant from the sides of the cradle.
- 3** Undo the slotted nut and bolt holding the knuckle (Figure 13) together and remove, allowing the two pieces of the knuckle to separate. This will provide access to the head of the Allen screw.
- 4** With a 4mm hexagonal screwdriver, fix knuckle to cradle by screwing Allen screw into one of the two threaded holes on the cradle.

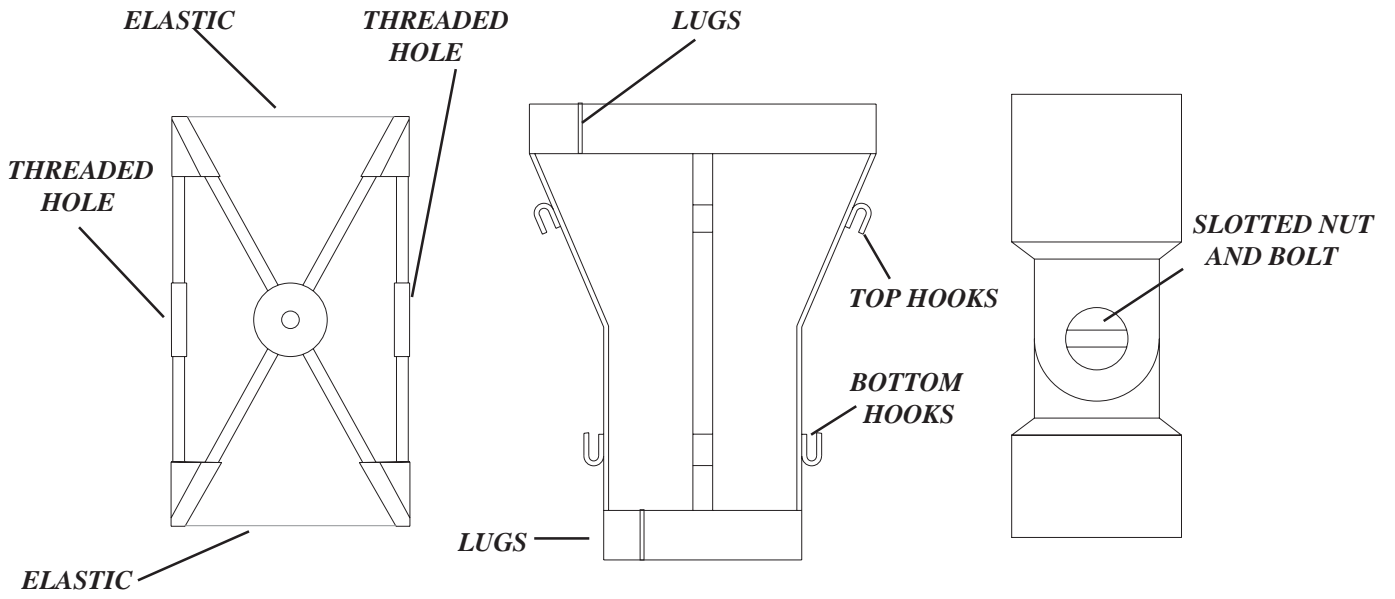

Fig 1 : Cradle

Fig 2 : Holder

Fig 3 : Knuckle

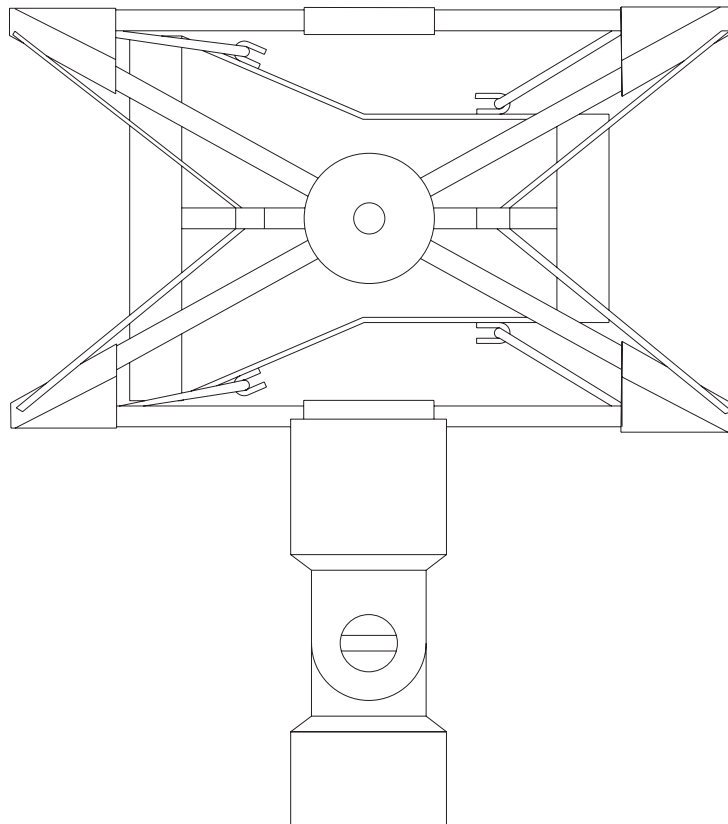
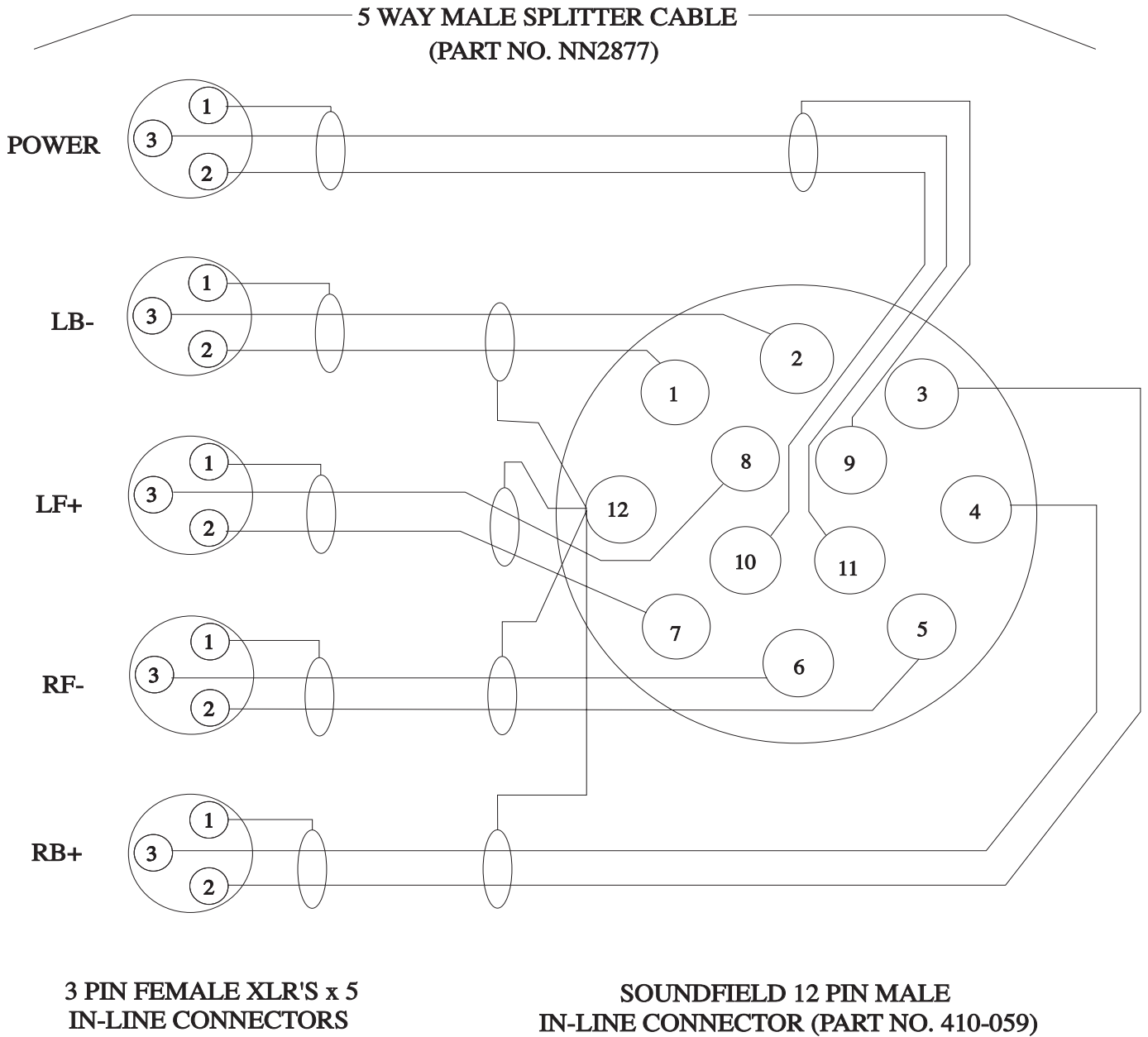
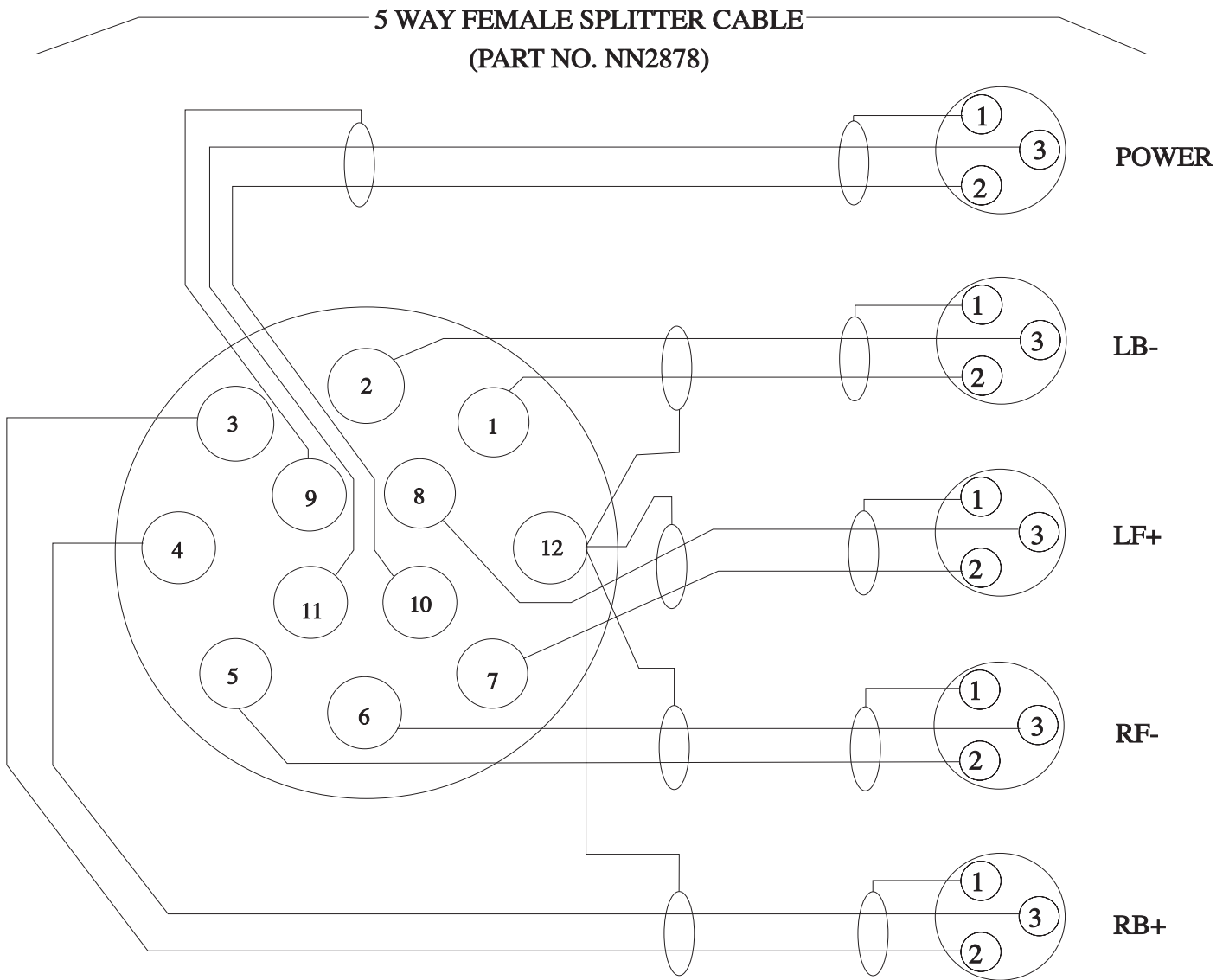

FIGURE 4 : ASSEMBLED SUSPENSION SYSTEM

Splitter Cable wiring details



ALL CONNECTIONS VIEWED FROM THE REAR



SOUNDFIELD 12 PIN FEMALE
IN-LINE CONNECTOR (PART NO. 410-045)

3 PIN MALE XLR'S x 5
IN-LINE CONNECTORS

ALL CONNECTIONS VIEWED FROM THE REAR

12 Pin Connector Wiring Details for SoundField Microphone Cables

12 Pin Male

Pin 1	-	LB (+)
Pin 2	-	LB (-)
Pin 3	-	RB (+)
Pin 4	-	RB (-)
Pin 5	-	RF (+)
Pin 6	-	RF (-)
Pin 7	-	LF (+)
Pin 8	-	LF (-)
Pin 9	-	Voltage GND
Pin 10	-	-V
Pin 11	-	+V
Pin 12	-	Signal GND

12 Pin Female

-	Pin 1
-	Pin 2
-	Pin 3
-	Pin 4
-	Pin 5
-	Pin 6
-	Pin 7
-	Pin 8
-	Pin 9
-	Pin 10
-	Pin 11
-	Pin 12

SoundField Colour Coding

Pin 1	-	White
Pin 2	-	Purple
Pin 3	-	Grey
Pin 4	-	Pink
Pin 5	-	Green
Pin 6	-	Yellow
Pin 7	-	Red
Pin 8	-	Blue
Pin 9	-	Black
Pin 10	-	Brown
Pin 11	-	Orange
Pin 12	-	Screen (plus link to connector chassis)

Important Note: Use colour coding as above as some wires have a different number of strands.